

Gage R&R Study - ANOVA Method

Inventory Item #: R00087-063-70SL

Gage Serial #: VX311HC01349

Date of study: 03/02/2017

Tolerance: ID .087+/- .005

Reported by: WF

Components of Variation

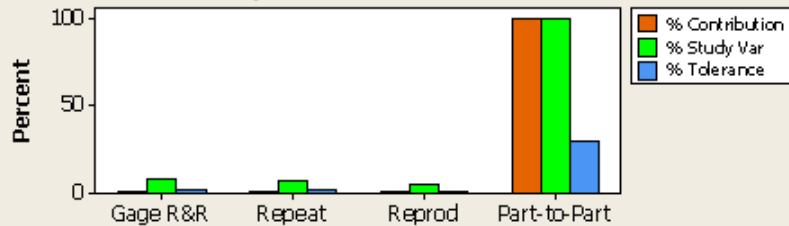

Measurements by Parts

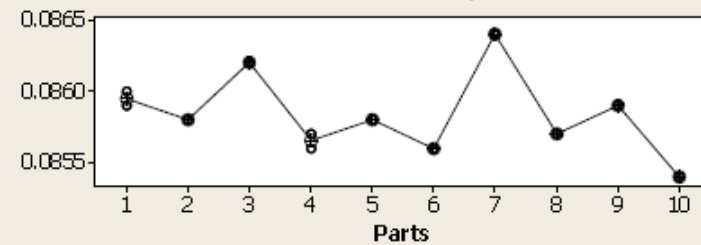

R Chart by Operators

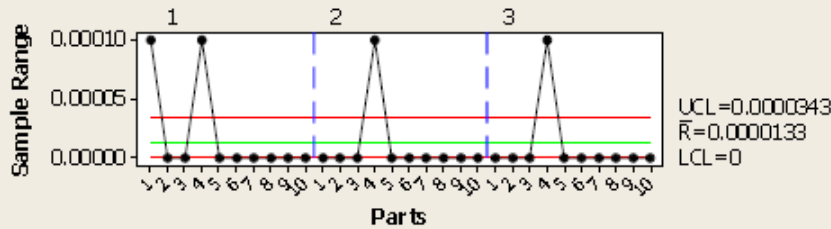

Measurements by Operators

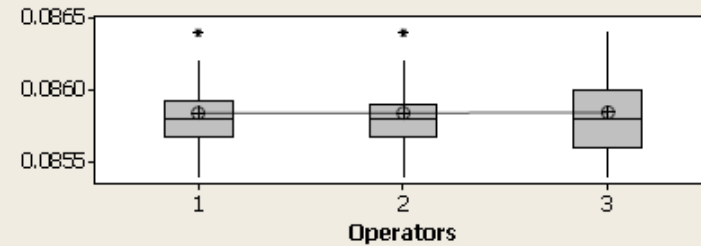

Xbar Chart by Operators

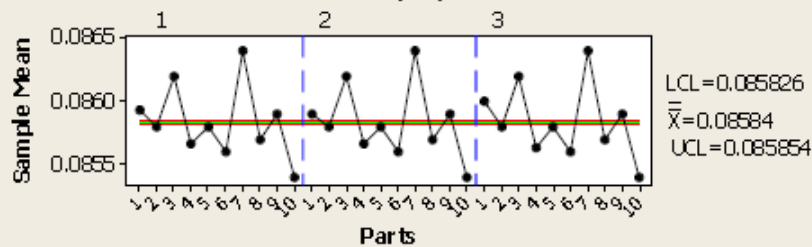

Parts * Operators Interaction

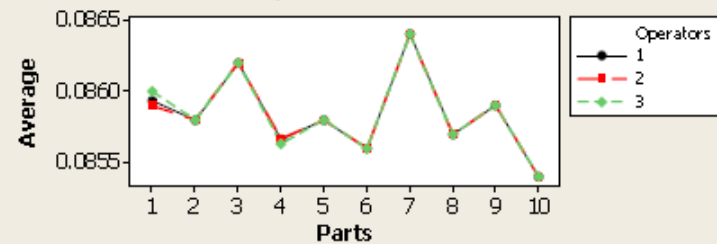

Two-Way ANOVA Table With Interaction

Source	DF	SS	MS	F	P
Parts	9	0.0000069	0.0000008	805.506	0.000
Operators	2	0.0000000	0.0000000	0.351	0.709
Parts * Operators	18	0.0000000	0.0000000	2.139	0.015
Repeatability	60	0.0000000	0.0000000		
Total	89	0.0000069			

Alpha to remove interaction term = 0.25

Gage R&R

Source	VarComp	%Contribution (of VarComp)
Total Gage R&R	0.0000000	0.72
Repeatability	0.0000000	0.52
Reproducibility	0.0000000	0.20
Operators	0.0000000	0.00
Operators*Parts	0.0000000	0.20
Part-To-Part	0.0000001	99.28
Total Variation	0.0000001	100.00

Process tolerance = 0.01

Source	StdDev (SD)	Study Var (10 * SD)	%Study Var (%SV)	%Tolerance (SV/Toler)
Total Gage R&R	0.0000248	0.0002476	8.46	2.48
Repeatability	0.0000211	0.0002108	7.21	2.11
Reproducibility	0.0000130	0.0001299	4.44	1.30
Operators	0.0000000	0.0000000	0.00	0.00
Operators*Parts	0.0000130	0.0001299	4.44	1.30
Part-To-Part	0.0002915	0.0029151	99.64	29.15
Total Variation	0.0002926	0.0029256	100.00	29.26

2.48 ≤ max requirement of 20 : Pass

Number of Distinct Categories = 16 ≥ minimum requirement of 5 : Pass

REV	DATE	DESCRIPTION	BY
A	01/01/17	O Ring	DM

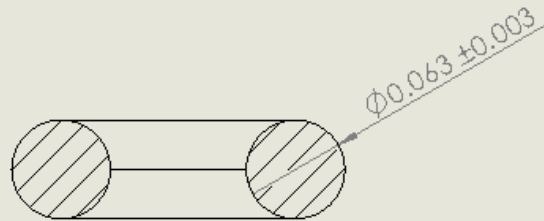
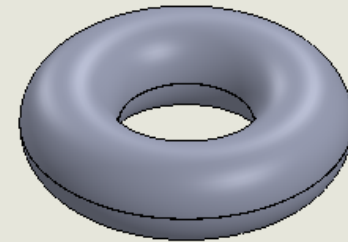
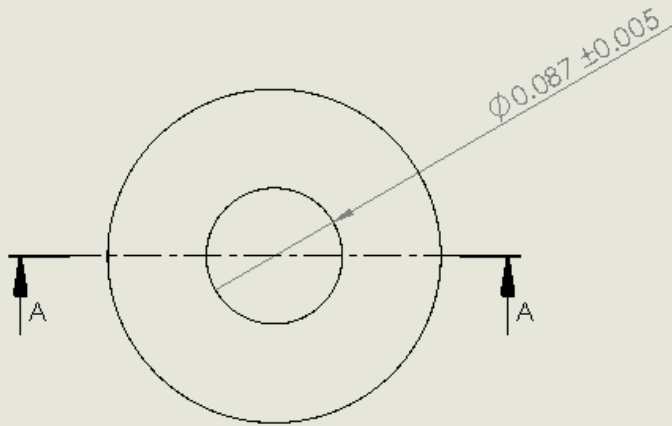

SECTION A-A

Material: 70 durometer Silicone Rubber

UNLESS OTHERWISE SPECIFIED RUBBER PRODUCT TOLERANCES ARE RMA STANDARD DESIGNATION "A" HIGH PRECISION			Customer XYZ	
SIZE (inches)	FIXED	CLOSURE	LANCASTER, NY 14086	
Above Incl.			**CONFIDENTIAL**	
0 - .40	+/- .004	+/- .005	COPYRIGHT 2002 APPLE RUBBER PRODUCTS, INC. THIS DOCUMENT CONTAINS CONFIDENTIAL PROPRIETARY INFORMATION AND IDEAS BELONGING TO APPLE RUBBER PRODUCTS, INC. NEITHER THIS DOCUMENT NOR ANY INFORMATION CONTAINED IN IT MAY BE USED FOR ANY OTHER PURPOSE, NOR REPRODUCED, COPIED OR DISCLOSED TO OTHER PARTIES WITHOUT THE PRIOR WRITTEN CONSENT OF APPLE RUBBER PRODUCTS, INC. THE MATERIALS BEING DISCLOSED IN CONFIDENCE FOR A LIMITED PURPOSE AND MUST BE RETURNED UPON REQUEST.	
.40 - .52	.005	.006		
.52 - 1.00	.006	.008		
1.00 - 1.40	.008	.010		
1.40 - 2.50	.010	.012		
2.50 - 4.00	.012	.016		
4.00 - 6.20	.016	.020		
			DRAWING TITLE:	
			O Ring	
			DRAWING NUMBER:	
			R00087-063-70SL	
			REV. A	A
			DM	01/01/17
			AJ	01/01/17
			SCALE	NIP, R00087-063-T0SL
			SHEET 1 OF 1	